

BONALDO

Dune

Designer: Giuseppe Viganò



Le ante frontali in legno sono caratterizzate da una superficie ondulata che crea un susseguirsi di luce e ombre, mentre la base metallica si sviluppa asimmetricamente e valorizza l'orizzontalità della madia. Dune è una madia moderna in legno dal carattere rigoroso, oltre che estremamente elegante e curata in ogni singolo dettaglio. Un elemento che si colloca perfettamente sia in una casa privata che in un ufficio. La madia Dune è disponibile in due diverse combinazioni di colore: struttura esterna in legno laccato bronzo, ante in noce Canaletto e base in metallo color bronzo oppure struttura esterna in legno laccato piombo, ante in rovere carbone e base in metallo color piombo.



Scheda tecnica

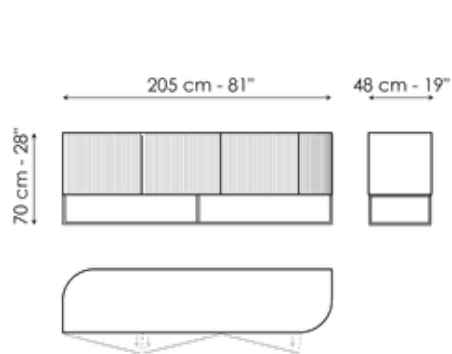

Dune

Larghezza: 205cm

Profondità: 48cm

Altezza: 70cm

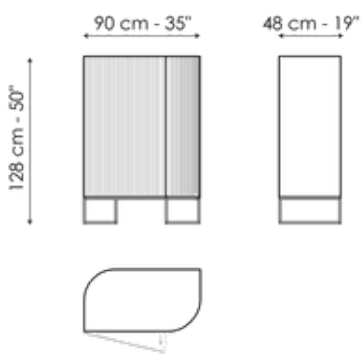

Dune high

Larghezza: 90cm

Profondità: 48cm

Altezza: 128cm

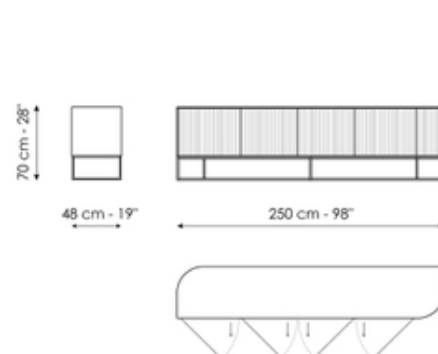

Dune 250

Larghezza: 250cm

Profondità: 48cm

Altezza: 70cm

Finishes

Struttura esterna



Legno laccato
Piombo opaco



Legno laccato
Bronzo opaco

Ante

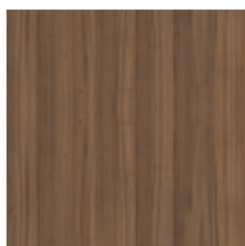

Legno impiallacciato
Noce Canaletto

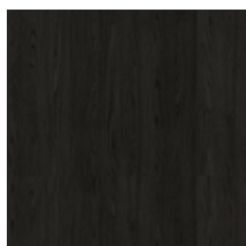

Legno impiallacciato
Rovere carbone

Base

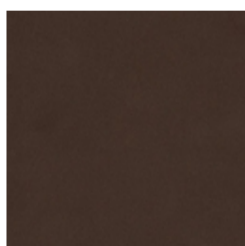

Metallo verniciato
Bronzo opaco

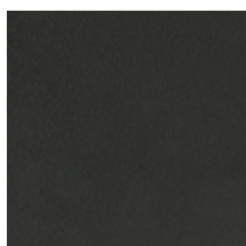

Metallo verniciato
Piombo opaco

Top - Dune 250

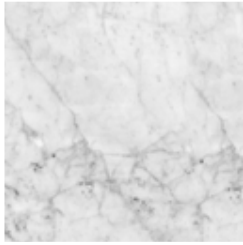

Marmo
Carrara

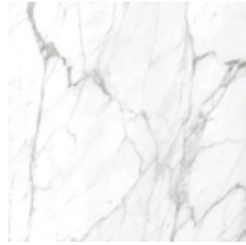

Marmo
Calacatta

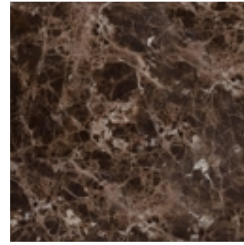

Marmo
Emperador

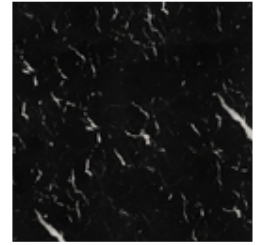

Marmo
Marquinia

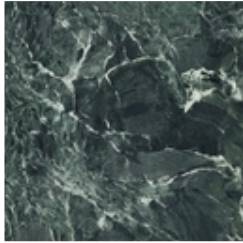

Marmo
Saint Denis

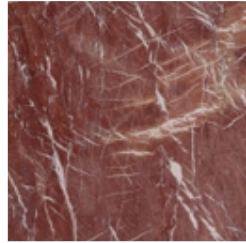

Marmo
Rosso Carpazi



Marmo
Fior di bosco



Marmo
Travertino Romano

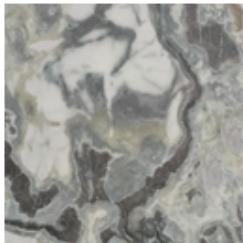

Marmo
Dover White

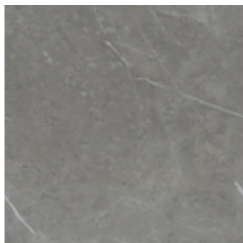

Ceramica opaca
Grigio Ardesia

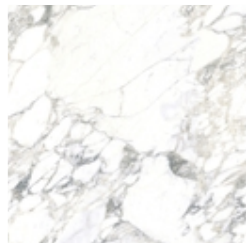

Ceramica lucida
Calacatta

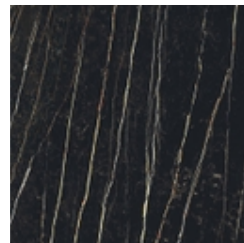

Ceramica opaca
Laurent

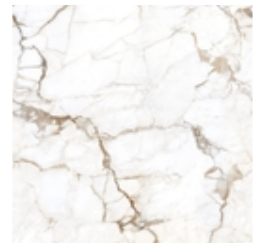

Ceramica finitura seta
Calacatta macchia vecchia

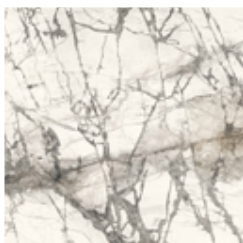

Ceramica lucida
Imperial grey

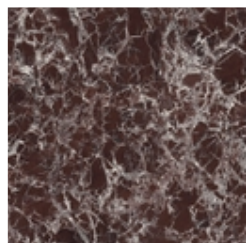

Ceramica lucida
Rosso imperiale

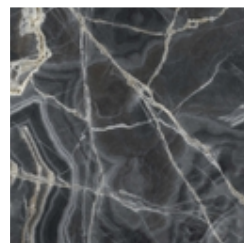

Ceramica lucida
Black Onyx



Ceramica lucida
Mountain peak

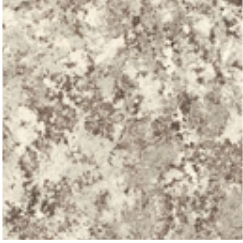

Ceramica opaca
Alaska White



Ceramica opaca
Augusta

Materiali, tessuti, colori e finiture sono puramente indicativi e possono variare da quelli attualmente rappresentati. Potete trovare la collezione completa di tessuti e pelli nel sito dedicato <https://bonaldo.biz>