

BONALDO

Art, Art Wood

Designer: Gino Carollo



La base del tavolo Art è l'elemento che lo identifica: un trapezio in metallo che si sviluppa diagonalmente rispetto al piano, che ottimizza gli spazi e li rende più ampi. Una struttura portante, che così progettata si contraddistingue per l'elevato dinamismo, la solidità e l'impatto scultoreo. Il piano vi si poggia saldamente, ma l'effetto finale è di grande leggerezza. La base di Art è in metallo verniciato in numerose varianti cromatiche; il piano, fisso (rettangolare, rotondo o a botte) oppure allungabile, è proposto in diversi materiali: una versatilità che lo rende ugualmente adatto alla sala da pranzo o allo studio. Art prende nuova vita nella sua versione con base in legno ("Art Wood").



Scheda tecnica

160 cm - 63"



90 cm - 35.4"



± 75 cm - 29.5"

Larghezza: 160cm
Profondità: 90cm
Altezza: ± 75cm

180 cm - 71"



90 cm - 35.4"

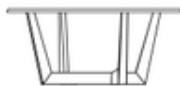

± 75 cm - 29.5"

Larghezza: 180cm
Profondità: 90cm
Altezza: ± 75cm

200 cm - 79"



100 cm - 39.4"



± 75 cm - 29.5"

Larghezza: 200cm
Profondità: 100cm
Altezza: ± 75cm

220 cm - 87"



100 cm - 39.4"



± 75 cm - 29.5"

Larghezza: 220cm
Profondità: 100cm
Altezza: ± 75cm

250 cm - 98"



100 cm - 39.4"



± 75 cm - 29.5"

Larghezza: 250cm
Profondità: 100cm
Altezza: ± 75cm

300 cm - 118"



108 cm - 42.5"



± 75 cm - 29.5"

Larghezza: 300cm
Profondità: 108cm
Altezza: ± 75cm

300 cm - 118"



120 cm - 47.2"



± 75 cm - 29.5"

Larghezza: 300cm
Profondità: 120cm
Altezza: ± 75cm

180 cm - 71"



100 cm - 39.4"



± 75 cm - 29.5"

Larghezza: 180cm
Profondità: 100cm
Altezza: ± 75cm

200 cm - 79"



108 cm - 42.5"



± 75 cm - 29.5"

Larghezza: 200cm
Profondità: 108cm
Altezza: ± 75cm

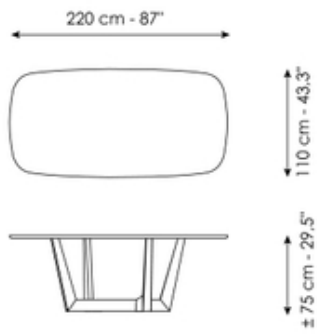

Larghezza: 220cm
 Profondità: 110cm
 Altezza: ± 75cm

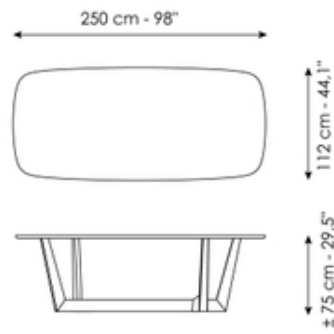

Larghezza: 250cm
 Profondità: 112cm
 Altezza: ± 75cm

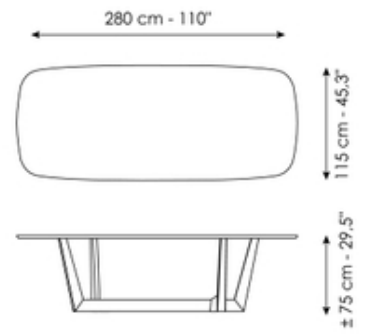

Larghezza: 280cm
 Profondità: 115cm
 Altezza: ± 75cm

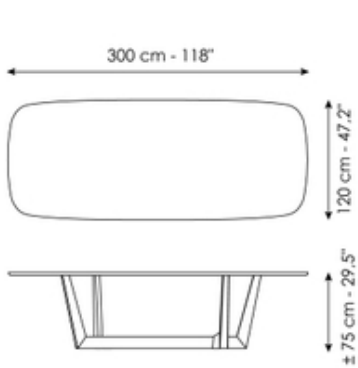

Larghezza: 300cm
 Profondità: 120cm
 Altezza: ± 75cm

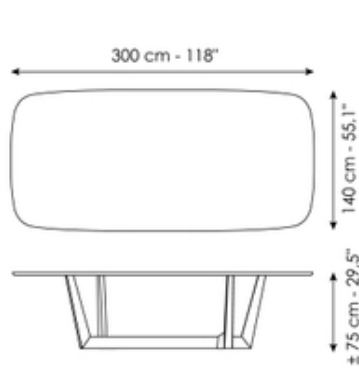

Larghezza: 300cm
 Profondità: 140cm
 Altezza: ± 75cm

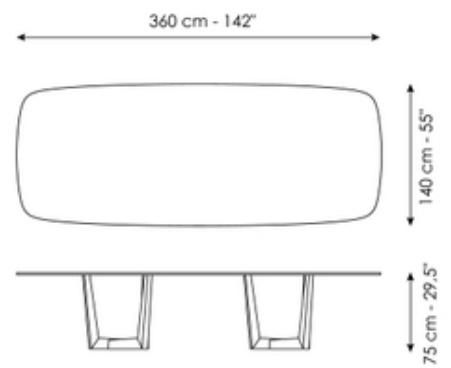

Larghezza: 360cm
 Profondità: 140cm
 Altezza: 75cm

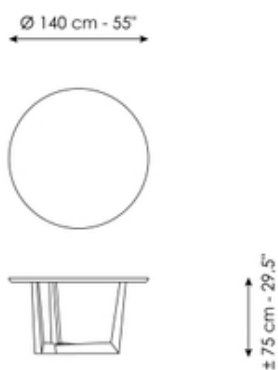

Larghezza: 140cm
 Profondità: 140cm
 Altezza: ± 75cm

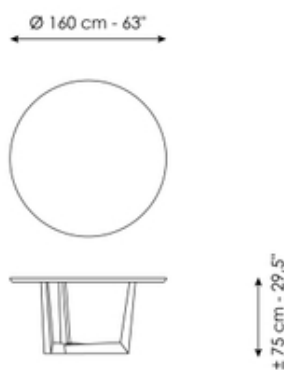

Larghezza: 160cm
 Profondità: 160cm
 Altezza: ± 75cm

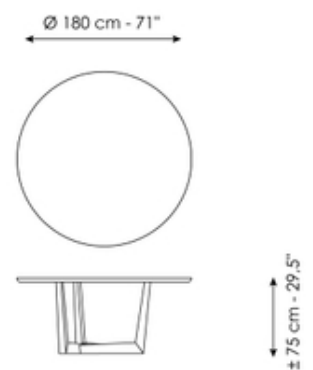

Larghezza: 180cm
 Profondità: 180cm
 Altezza: ± 75cm

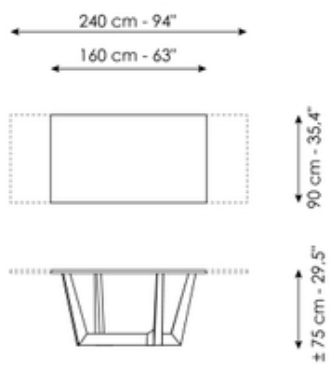

Larghezza: 160/240cm
Profondità: 90cm
Altezza: ± 75cm

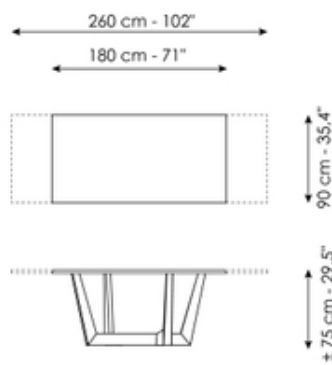

Larghezza: 180/260cm
Profondità: 90cm
Altezza: ± 75cm

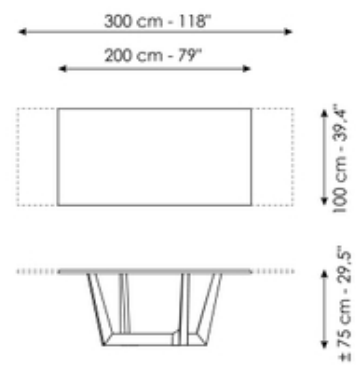

Larghezza: 200/300cm
Profondità: 100cm
Altezza: ± 75cm

Finishes

Piano

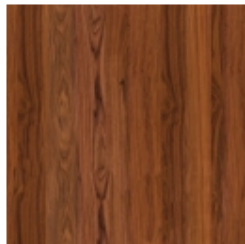

Legno massello
Noce americano

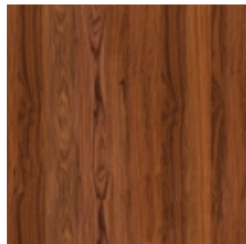

Legno con bordi naturali
Noce americano

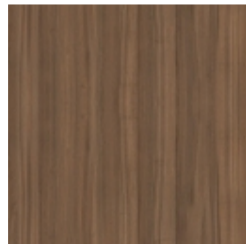

Legno impiallacciato
Noce Canaletto

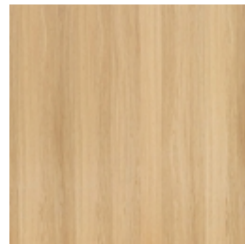

Legno impiallacciato
Rovere spazzolato naturale

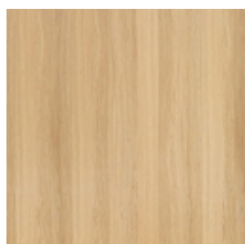

Legno massello
Rovere spazzolato naturale

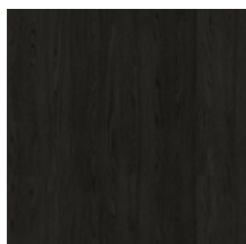

Legno impiallacciato
Rovere spazzolato carbone

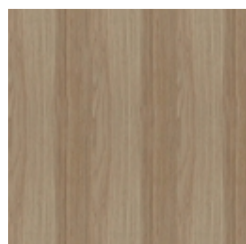

Legno impiallacciato
Rovere Grey spazzolato



Legno massello
Rovere spazzolato Grey

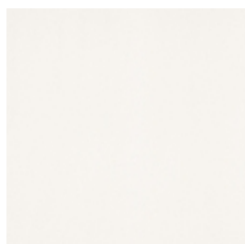

Ceramica opaca
Bianco iridium

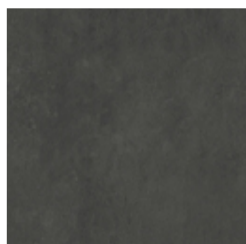

Ceramica opaca
Grigio grafite

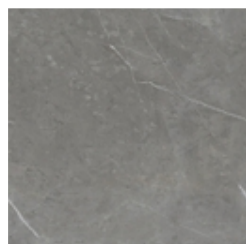

Ceramica opaca
Grigio Ardesia



Ceramica lucida
Calacatta

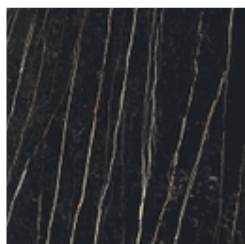

Ceramica opaca
Laurent



Ceramica finitura seta
Calacatta macchia vecchia

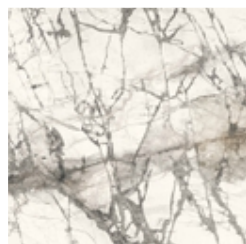

Ceramica lucida
Imperial grey

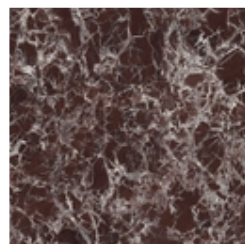

Ceramica lucida
Rosso imperiale

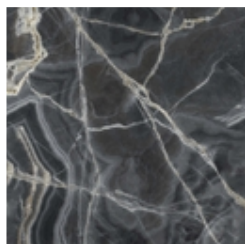

Ceramica lucida
Black Onyx

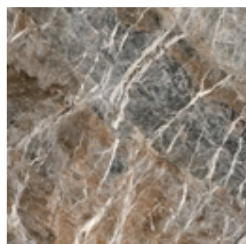

Ceramica lucida
Mountain peak

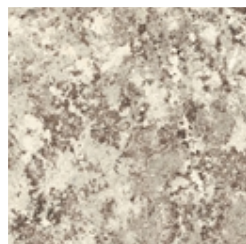

Ceramica opaca
Alaska White



Ceramica opaca
Augusta

Piano

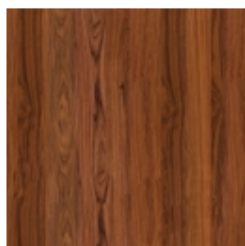

Legno massello
Noce americano

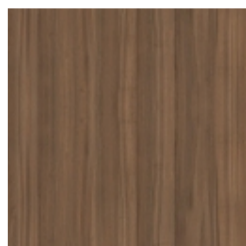

Legno impiallacciato
Noce Canaletto

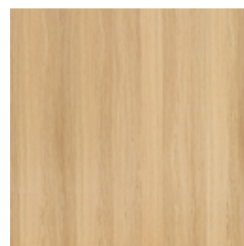

Legno massello
Rovere naturale



Legno massello
Rovere spazzolato Grey

Cristallo
Trasparente



Cristallo
Fumè



Cristallo
Bronzato

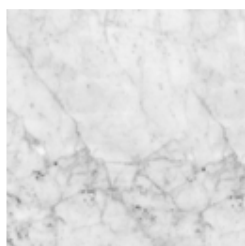

Marmo
Carrara

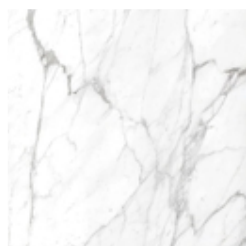

Marmo
Calacatta

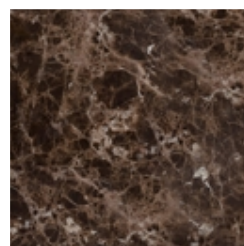

Marmo
Emperador

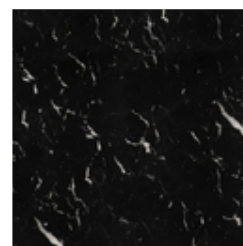

Marmo
Marquinia

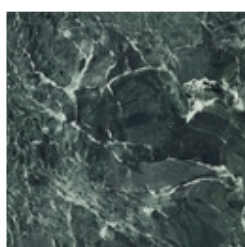

Marmo
Saint Denis



Marmo
Rosso Carpazi

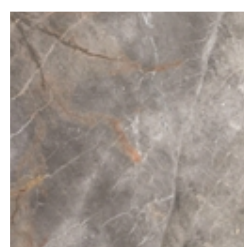

Marmo
Fior di bosco



Marmo
Travertino Romano

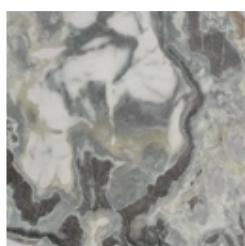

Marmo
Dover White

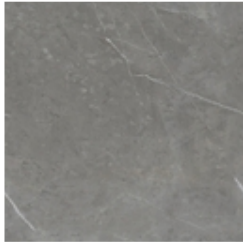

Ceramica opaca
Grigio Ardesia

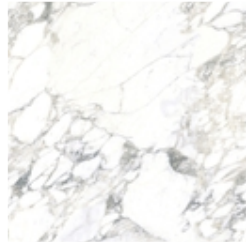

Ceramica lucida
Calacatta

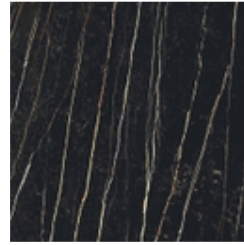

Ceramica opaca
Laurent



Ceramica finitura seta
Calacatta macchia vecchia

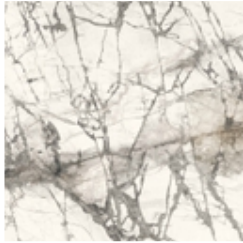

Ceramica lucida
Imperial grey

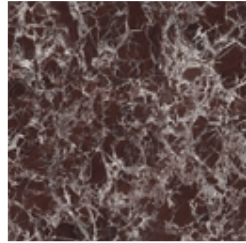

Ceramica lucida
Rosso imperiale

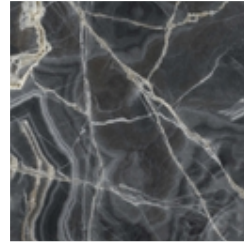

Ceramica lucida
Black Onyx

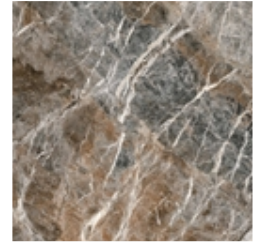

Ceramica lucida
Mountain peak

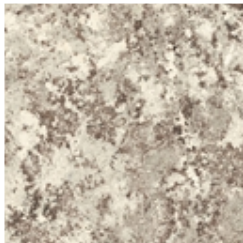

Ceramica opaca
Alaska White



Ceramica opaca
Augusta

Piano

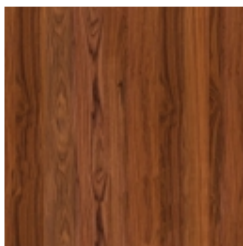

Legno massello
Noce americano



Legno massello
Rovere spazzolato naturale

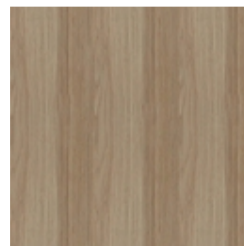

Legno massello
Rovere spazzolato Grey

Cristallo
Trasparente



Cristallo
Fumè



Cristallo
Bronzato

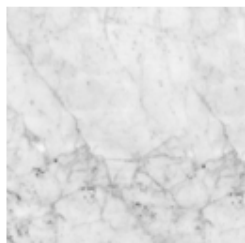

Marmo
Carrara

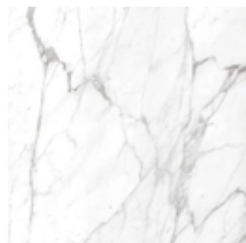

Marmo
Calacatta

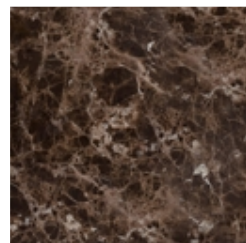

Marmo
Emperador

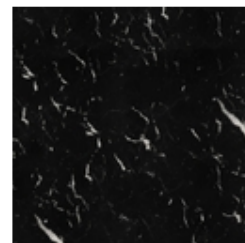

Marmo
Marquinia

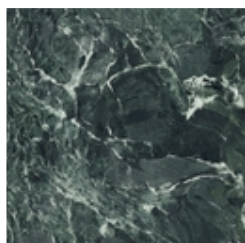

Marmo
Saint Denis



Marmo
Rosso Carpazi

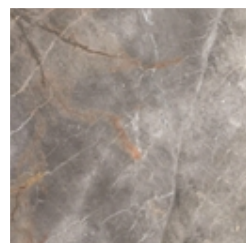

Marmo
Fior di bosco

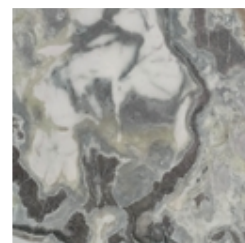

Marmo
Dover White

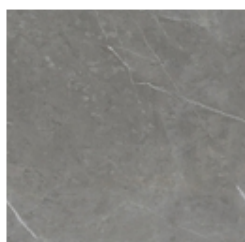

Ceramica opaca
Grigio Ardesia

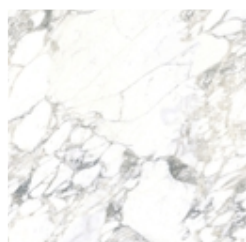

Ceramica lucida
Calacatta

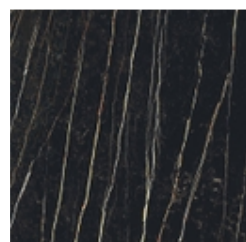

Ceramica opaca
Laurent



Ceramica finitura seta
Calacatta macchia vecchia

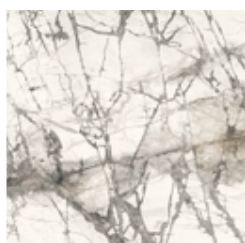

Ceramica lucida
Imperial grey

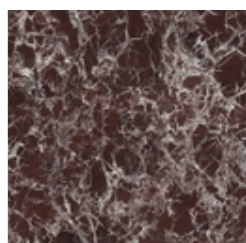

Ceramica lucida
Rosso imperiale

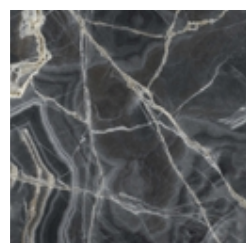

Ceramica lucida
Black Onyx

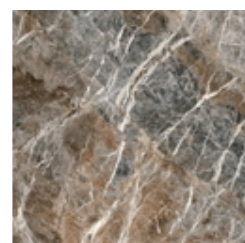

Ceramica lucida
Mountain peak

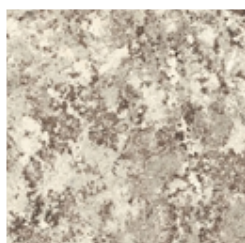

Ceramica opaca
Alaska White



Ceramica opaca
Augusta



Legno impiallacciato
Noce Canaletto



Legno impiallacciato
Rovere spazzolato carbone



Legno impiallacciato
Rovere Grey spazzolato

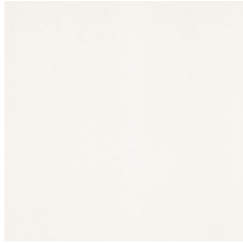

Ceramica opaca
Bianco iridium



Ceramica opaca
Grigio grafite

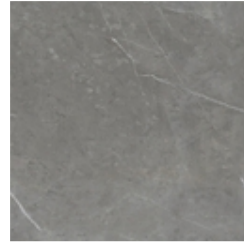

Ceramica opaca
Grigio Ardesia

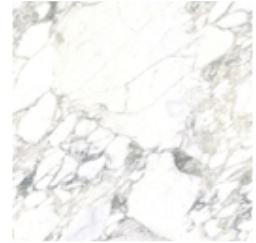

Ceramica lucida
Calacatta

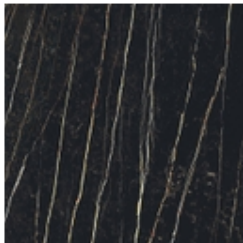

Ceramica opaca
Laurent



Ceramica finitura seta
Calacatta macchia vecchia

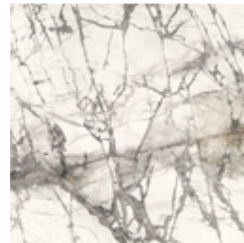

Ceramica lucida
Imperial grey

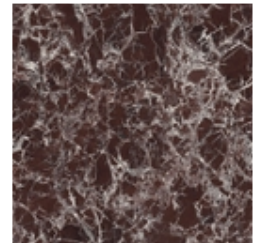

Ceramica lucida
Rosso imperiale

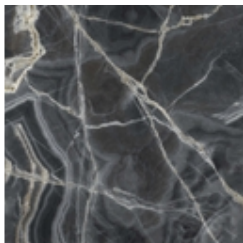

Ceramica lucida
Black Onyx



Ceramica lucida
Mountain peak

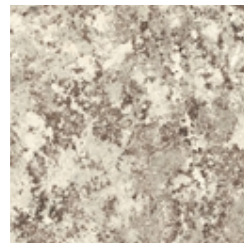

Ceramica opaca
Alaska White



Ceramica opaca
Augusta

Base

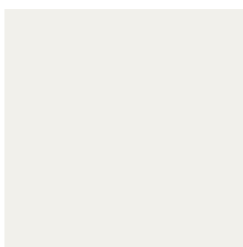

Metallo verniciato
Bianco opaco

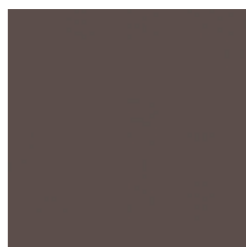

Metallo verniciato
Marrone opaco



Metallo verniciato
Supreme anthracite



Metallo verniciato
Nero opaco



Metallo verniciato
Tortora opaco



Metallo verniciato
Rame opaco



Metallo verniciato
Ottone opaco



Metallo verniciato
Bronzo opaco



Metallo verniciato
Piombo opaco



Metallo verniciato
Oro perlato opaco



Metallo finitura
Clouded chrome



Metallo finitura
Brown nickel



Metallo finitura
Dark nickel

Base

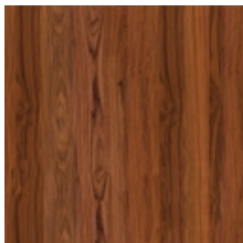

Legno massello
Noce americano

Materiali, tessuti, colori e finiture sono puramente indicativi e possono variare da quelli attualmente rappresentati. Potete trovare la collezione completa di tessuti e pelli nel sito dedicato <https://bonaldo.biz>