

ECH9



LA VERSATILITÀ DEL PROGETTO DEL 1927 DI CHARLOTTE PERRIAND PER IL SUO APPARTAMENTO PARIGINO DI PLACE SAINT-SULPICE ISPIRA QUESTA FAMIGLIA DI SEDUTE CARATTERIZZATA DA SCHIENALE ADATTIVO. EXTENDO LA REINTERPRETA DISEGNANDO LA VERSIONE CON BRACCIOLI CHE NE CONSENTE LA COMPLETA ROTAZIONE AL DI SOTTO DEL TOP TAVOLO, AGEVOLANDO L'ACCESSIBILITÀ ALLA SEDUTA.

The versatility of the 1927 project of Charlotte Perriand for his Parisian apartment in Place Saint-Sulpice inspires this family of chairs with adjustable back. Extendo re-interprets it, designing a version with arms that allows full rotation under the table top, facilitating accessibility and seating.

La versatilité du projet de 1927 de Charlotte Perriand pour son appartement parisien de la place Saint-Sulpice inspire cette famille de sièges caractérisée par leur dossier adaptatif. Extendo propose une réinterprétation avec une version à accoudoirs et rotation complète sous le plateau de la table pour faciliter l'accès au siège.

Die Vielseitigkeit des Projekts von 1927 von Charlotte Perriand für sein Pariser Apartment am Place Saint-Sulpice inspiriert diese durch die adaptive Rückenlehne gekennzeichnete Familie von Sitzmöbel. Extendo interpretiert sie neu und entwirft die Version mit Armlehnen, die die komplette Drehung unterhalb der Tischplatte ermöglichen und so das Sitzen erleichtern.

La versatilidad del diseño de Charlotte Perriand de 1927 para su piso parisino de la plaza Saint-Sulpice inspiró esta familia de sillas con respaldo adaptable. Extendo lo reinterpreta diseñando una versión con reposabrazos que le permite girar completamente por debajo del tablero, facilitando el acceso al asiento.



Schienale adattivo
Adjustable backrest
Dossier adaptatif
Adaptive Rückenlehne
Respaldo adaptable



ADAPTIVE
CHAIR BACKREST
registered community
design



Sfoderabile
Removable upholstery
Déhoussable
Abnehmbares Polsterzeug
Cubierta desmontable



Piedini intercambiabili
Interchangeable feet
Pieds interchangeables
Austauschbare Füße
Pies intercambiables

FINITURE/FINISHES

fondello e schienale / seat and back

	essenze woods		Y36 rovere oak		Y34 noce walnut		Y37 rovere affumicato smoked oak		Y40 frassino argilla clay ash		Y39 frassino nero black ash		
	cuoio cow-hide		F01 tabacco tobacco		F02 nero black								
	100% poliestere/polyester peso/weight: 400 gr/mq BSI : 50.000 cicli/cycles		JA01 perla pearl		JA02 avorio ivory		JA03 fangio mud		JA04 salvia sage		JA05 oliva olive		JA06 cipria powder pink
	50% cotone/cotton 40% poliestere/polyester 10% poliacrilico/polyacrylic peso/weight: 430 gr/mq BSI : 40.000 cicli/cycles		JB01 natur natur		JB02 ecru ecru		JB03 grigio grey		JB04 cenere ash		JB05 platino platinum		JB06 antracite anthracite
	60% lino/linen 40% viscosa/viscose peso/weight: 550 gr/mq BSI : 20.000 cicli/cycles		JC01 fumo smoke		JC02 cenere ash		JC03 sacco sack		JC04 terra land		JC05 verde green		JC06 rosa pink

telaio / structure

	acciaio verniciato painted steel		C12 bianco white		C21 seta silk		C23 corda ecru		C30 ghisa cast-iron		C14 antracite anthracite		C08 nero black
			C18 verde green		C26 corten corten		C29 bronzo bronze		C37 rame copper		C38 titanio titanium		

DIMENSIONI/DIMENSIONS

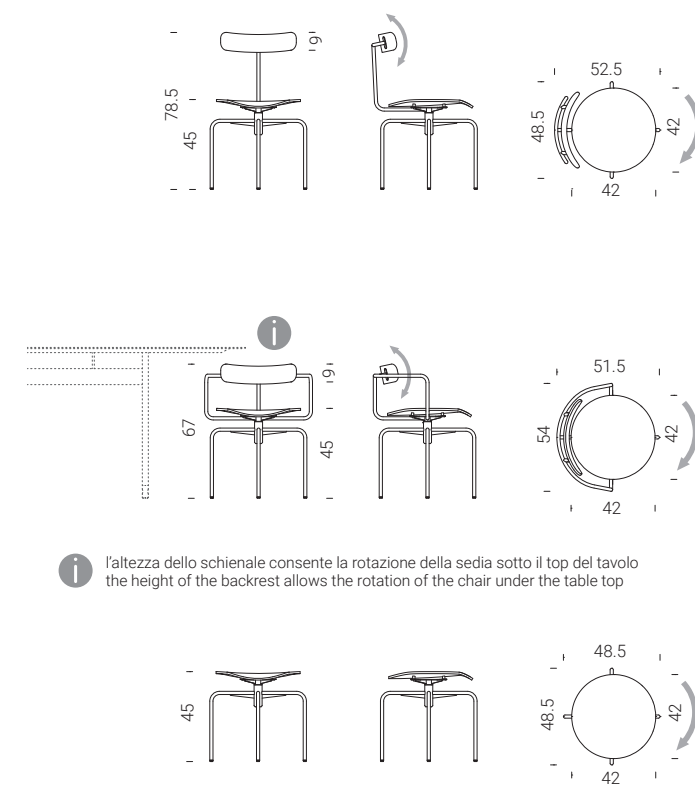

⚠ verificare a listino disponibilità, composizione e consigli di lavaggio per i tessuti.
check availability, composition and washing recommendations for fabrics in the price list.