

MJA LIMITED EDITION

Design Jacques Adnet, 1930

Lampada da tavolo disegnata nel 1930 da Jacques Adnet esponente di spicco del Modernismo francese e, in quegli anni, direttore de "La Compagnie des Arts Français" in cui operarono Francois Jourdain, Charlotte Perriand e Georges Jouve. MJA (Memory of Jacques Adnet) entrò in produzione solo nel 2005; in precedenza non fu mai realizzata se non a livello di prototipo. La lampada, composta da una calotta sferica poggiata su un piedistallo dalla forma quadrangolare, realizzata in ottone con finitura Palladio o in Oro Zecchino.

Table lamp designed in 1930 by Jacques Adnet great exponent of French Modernism. During those years he was director of "La Compagnie des Arts Français" where Francois Jourdain, Charlotte Perriand and Georges Jouve worked too. MJA (Memory of Jacques Adnet) in production from 2005, was earlier only realized as a prototype. The lamp, with a spherical cap resting upon a quadrangular base, is made of brass with a Palladium or Gold finishes.

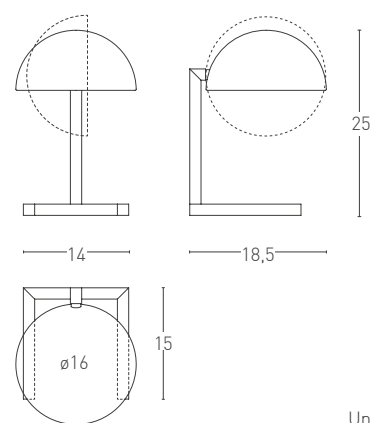
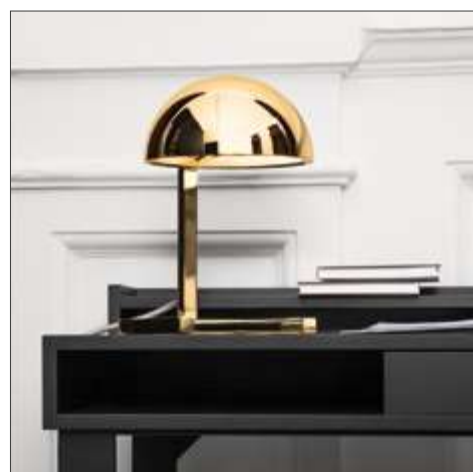

Units: cm



Finishes

- 160 Palladium
- 154 Gold

Cable

Transparent

Suggested light source

220/240V E14

100/120V E12

Halogen ECO max 30W

LED

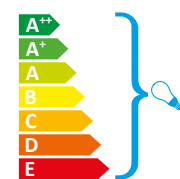

Certification

